

Vehicle Standards Bulletin 14

**NATIONAL CODE OF PRACTICE
for
LIGHT VEHICLE CONSTRUCTION
and
MODIFICATION**

**SECTION LL
MOTOR CYCLES & THREE WHEELED
VEHICLES**

VERSION 2.0 JANUARY 2011

Vehicle Standards Bulletin 14

National Code of Practice for Light Vehicle Construction and Modification (VSB 14)

Important Information for Users

Users of VSB 14 need to be aware that this document needs to be used in conjunction with the appropriate administrative requirements of the jurisdiction in which they wish to either register a vehicle or to obtain approval for a modification for an already registered vehicle. *Administrative requirements* include, amongst other things, processes for vehicle registration, obtaining exemptions, obtaining modification approvals, vehicle inspections, preparation and submission of reports and the payment of appropriate fees and charges.

If unsure of any of the requirements specified in VSB 14, or if more information is needed for any other issues concerning the administrative requirements, users should contact their relevant Registration Authority **prior** to commencing any work.

While VSB 14 provides advice on the construction of Individually Constructed Vehicles (ICVs) and the execution of modifications, it is not to be taken to be a design manual. Determination of component strength, performance, suitability and functionality must be either calculated or determined on a case by case basis by suitably qualified personnel experienced in each matter under consideration.

Users of VSB 14 also need to ensure that they refer to the most recent version of the relevant Section/s when working on a project. The version is identified by the version number and date on the face page of each Section. The version and date is also located in the footer of each page in each Section. On the website the version number is specified in the Section file name for easy identification.

If a project is taking a long time to complete, check the currency of the version you are using.

Users must be familiar with the provisions stated in the Preface and Introduction. These two Sections provide the necessary background information to assist users in understanding how VSB 14 is administered by Registration Authorities across Australia, on how it is structured, and the meaning of the types of modification codes specified in VSB 14. If not already done so, users should download them for study and reference.

Understanding these requirements is important to ensure that the correct processes are followed thereby reducing the likelihood of having work rejected by Registration Authorities.

Many of the Sections refer to other Sections within VSB 14 for further information or additional requirements. Users must read and apply all relevant Sections.

If in doubt about any issue concerning or contained in VSB 14, users should seek clarification from the appropriate State or Territory Registration Authority.

Please do not contact Vehicle Safety Standards (VSS) of the Australian Government Department of Infrastructure and Transport in Canberra about VSB 14. VSS provides the website as a service only.

Document Amendments by Version

Version

**Version 2.0
Published 1 January 2011**

Amendments

Codes for converting seat from two to single seater and vice versa have now been relegated to modifications that do not require certification.

This document has also a number of editorial amendments that have had no affect on its technical content.

CONTENTS

	Page
1 Scope	5
1.1 Basic Modifications Not Requiring Certification	5
1.2 Certified Modifications	5
2 General Requirements	5
2.1 Design	6
2.2 Fabrication	13
3 Australian Design Rules	14
4 Non-certified Modifications	14
4.1 Optional Components Offered by the Manufacturer	15
5 Specific Requirements for Seat Conversions	15
5.1 Conversion From Two Seater to Single Seater	15
5.2 Conversion From A Single Seater to A Two Seater Original	16
6 Certified Modifications (LL Codes)	16
LL1 to LL7 Not currently in use	

1 SCOPE

This Section outlines the minimum design, installation and fabrication requirements for the following modifications involving motor cycles and other Australian Design Rule (ADR) category *L-group* vehicles.

This Section must not be used for the construction of Individually Constructed Vehicles including motor cycles and other ADR category *L-group* vehicles. Section LO must be used for this purpose.

Section LO provides information on the construction of ICVs for:

- motor cycles ADR category LA, LB, LC and LD; and
- guidelines together with checklists for LEM1 and LEP1, ADR category tricycles.

1.1 BASIC MODIFICATIONS NOT REQUIRING CERTIFICATION

The following are *Basic Modifications* that may be performed without certification provided they are carried out in compliance with the requirements detailed in sub-section 2 *General Requirements*:

- Fitting a manufacturer's optional component such as an engine, transmission, exhaust system or fuel tank for the particular make/model of the vehicle in question. (Note that replacing parts or components of a motor cycle with the manufacturer's parts or equivalent components does not fall into the category of *modifications* and as a consequence no approvals are necessary for repair work);
- Conversion of a two-seat motor cycle to a single seater; and
- Conversion of a modified motor cycle to original seating configuration.

Note: The underlying design installation and fabrication requirements for all of the above modifications are contained in sub-section 2 *General Requirements*.

1.2 CERTIFIED MODIFICATIONS

There are no certified modifications currently under this Code.

2 GENERAL REQUIREMENTS

This sub-section applies to all light vehicles and must be read and applied in conjunction with all the Section LL Codes applicable to the proposed modifications.

Modified vehicles, including motor cycles, must continue to comply with the ADRs to which they were originally constructed, except as allowed for in the Australian Vehicle Standards Rules (AVSR). These modified vehicles must also comply with the applicable in-service requirements of the AVSR.

Modified pre-ADR vehicles must continue to comply with the AVSR.

Compliance with the AVSR also means compliance with the equivalent regulations of a State or Territory of Australia.

The alterations must not affect the safe handling of the motor cycle or endanger either the rider or any other road user. In addition, the motor cycle must not be altered in any way such that it will create a nuisance either to other road users or to any member of the public.

2.1 DESIGN

2.1.1 Dimensional Requirements - Motor Cycles Without a Sidecar

The maximum width including the load and equipment must not exceed 1 metre.

The load or equipment must not project more than 150mm beyond the extreme outer portion of the motor cycle on either side.

The maximum longitudinal projection beyond the outer extremity of the tyres of any part of the motor cycle and loading or equipment thereon must **not** exceed 150mm in the case of the front tyre and 300mm in the case of the rear tyre.

If the motor cycle is fitted with a *sisy* bar it must not have any sharp points or edges or be of a design that interferes with the safe operation of the motor cycle.

2.1.2 Ground Clearance

When laden, the ground clearance must not be less than 100mm, measured from a horizontal road surface to any point on the underside of the motor cycle or sidecar excluding tyres wheels and hubs.

2.1.3 Seating

All seats for the rider or pillion passenger must be securely attached to the vehicle. *Stick-on* or suction cup methods of attachment must not be used.

2.1.4 Brakes

The vehicle must be equipped with either a *Split Service Brake System* or independently actuated service brake systems. Vehicles that have independently actuated service brake systems must have two independent brake systems, one capable of acting on the front wheel and the other on the rear wheel(s).

Failure of any component in a mechanical service brake system must not result in a loss of braking ability in the other service brake system.

A leakage type failure in a hydraulic split service brake system must not result in a loss of braking ability in the other brake circuit.

Each vehicle manufactured after 1 July 1988 and equipped with a hydraulic brake system must meet the reservoir capacity requirements of ADR33/00.

The service brake system must be installed so that the lining thickness of drum brake shoes may be visually inspected, either directly or by the use of a mirror without removing the drums, and so that disc brake friction lining thickness may be visually inspected without removing the pads.

The controls by which brakes are actuated must be located so that they are readily accessible to the driver in the normal driving position.

The operation of each brake control must cause the brake lamp/s to illuminate.

2.1.5 Sidecars

Sidecars must only be fitted to the left hand side of a motor cycle.

The maximum width of the combination, including any load and equipment, must not exceed 1.85m.

Any load or equipment must not project more than 150mm beyond the extreme outer portion of the vehicle on either side.

The overhang of any load or equipment forward of the front tyre must not exceed 600mm. The overhang of any load or equipment rearward of the rear tyre must not exceed 900mm.

2.1.6 Stand

Any stand fitted to a motor cycle must be maintained in an efficient and safe condition and must be equipped with a spring or other device capable of holding it securely in the *up* position at all times when the stand is not in use.

For all LA and LC group motor cycles manufactured after 1 July 1998, a stand must be fitted that is capable of holding the motor cycle in a substantially upright position. The stand may be of the side or centre type and must be equipped with a spring or other device capable of securely holding it clear of the road at all times when the stand is not in use. A side stand must be designed so that it does not remain in the *down* position when the vehicle is moving or about to move.

2.1.7 Foot Rests or Foot Pegs

Every motor cycle must be fitted with adequate foot rests or foot pegs for the rider and, in the case where a pillion seating position is provided, foot rests for the pillion passenger.

2.1.8 Rear Vision Mirrors

A motor cycle and motor tricycle built before July 1975 must have at least one mirror on the right hand side.

A motor cycle or motor tricycle with one front wheel, built after July 1975, must be equipped with two rear vision mirrors symmetrically placed relative to the centre of the handlebars.

The rear vision mirror or mirrors must be fitted so as to allow the rider to clearly see, by reflection, the road behind the vehicle and any following or overtaking vehicles. For circular mirrors the reflective surface area must have a minimum diameter of 94mm and for non-circular mirrors the reflective surface must be not less than 78mm in diameter and at least 120mm by 200mm.

If a mirror has a convex surface it must have a radius of curvature not less than 1200mm.

Motor cycles and motor tricycles may be fitted with additional mirrors that are flat or convex or a combination of these surfaces.

2.1.9 Mudguards

Mudguards must be fitted to all wheels, including sidecar wheels (refer to Figure LL1 for details of mudguard construction and location). Each mudguard must be at least as wide, over its entire length, as its respective wheel and tyre.

A front wheel mudguard must cover the rearward section of the wheel through the area between two lines, one vertical and the other horizontal, both drawn through the centre of the wheel. If suitable protection is afforded by the frame or construction of the motor cycle, the front mudguard need only cover the area that is unprotected.

A rear wheel or sidecar wheel mudguard must extend at least from a point vertically above the front of the tyre to a point vertically above the rear of the tyre.

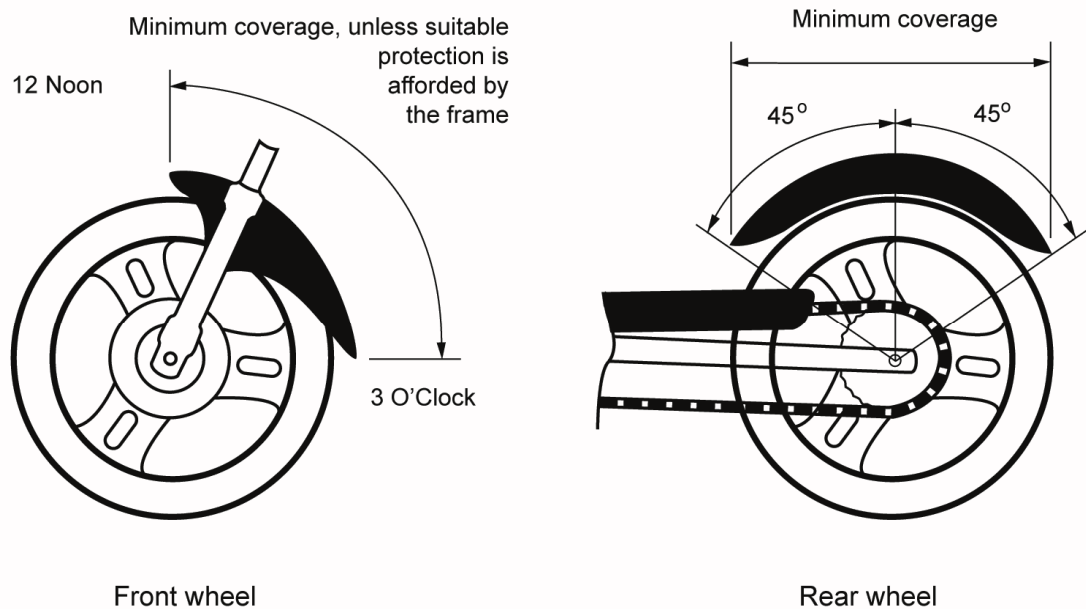

Figure LL1 Mudguard Dimensions

2.1.10 Foot and Hand Controls

The controls for motor cycles are standardised, therefore the position and operation of foot and hand controls must be kept, as far as practicable, to the manufacturer's original specification. For example, if the rider's footrests are moved rearwards (that is, converted to *rear seats*) the gear lever must not be reversed or inverted. For safety reasons, the only acceptable method for this conversion is to fit a linkage, which keeps the gear change pattern the same as the original. Riders should always be able to operate the brake pedal without lifting their foot from the footrest.

2.1.11 Drive Guards (Refer to Figure LL2)

If the motor cycle is chain or belt driven and the construction of the frame is not sufficient to protect the rider and/or the pillion passenger from the driving sprocket and the upper run of the chain or belt, the motor cycle must be fitted with a guard. The guard must extend at least 300mm rearward of the rearmost footrest or to the vertical centre of the rear sprocket, whichever is the lesser.

Primary drives must also be similarly protected.

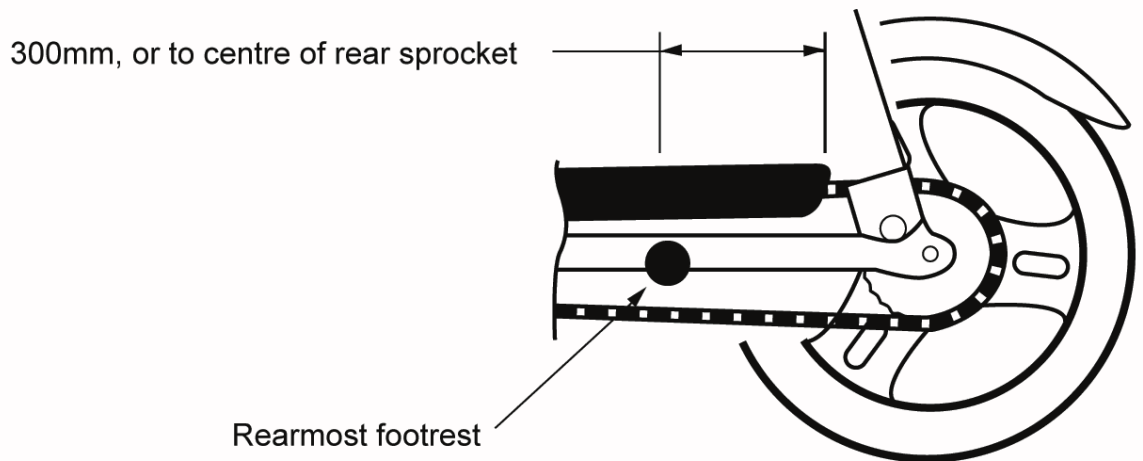

Figure LL2 Chain Guard Dimensions

2.1.12 Frame or Suspension Modifications

Motor cycle design is a complex task. Modifications made to a motor cycle's frame or suspension, can adversely affect the structural integrity of the frame, steering head, front forks and suspension increasing the risk of component failure. Similarly, braking and wheel loading may be adversely affected.

Motor cycles with custom frames, extended forks or structural modifications require an engineering report.

When forks are extended, without modifications to the frame, care must be taken to ensure the vehicle continues to comply with ADR57 with respect to special requirements for L-group vehicles. The horizontal distance between the mid-point of the steering yoke bearings and a point vertically above the centre of the front wheel must not exceed 550mm.

A motor cycle with a specially designed and constructed frame will be considered to be an *Individually Constructed Vehicle*.

Note: Section LO provides information on the construction of ICVs for:

- motor cycles ADR category LA, LB, LC and LD; and
- guidelines together with checklists for LEM1 and LEP1, ADR Category Tricycles.

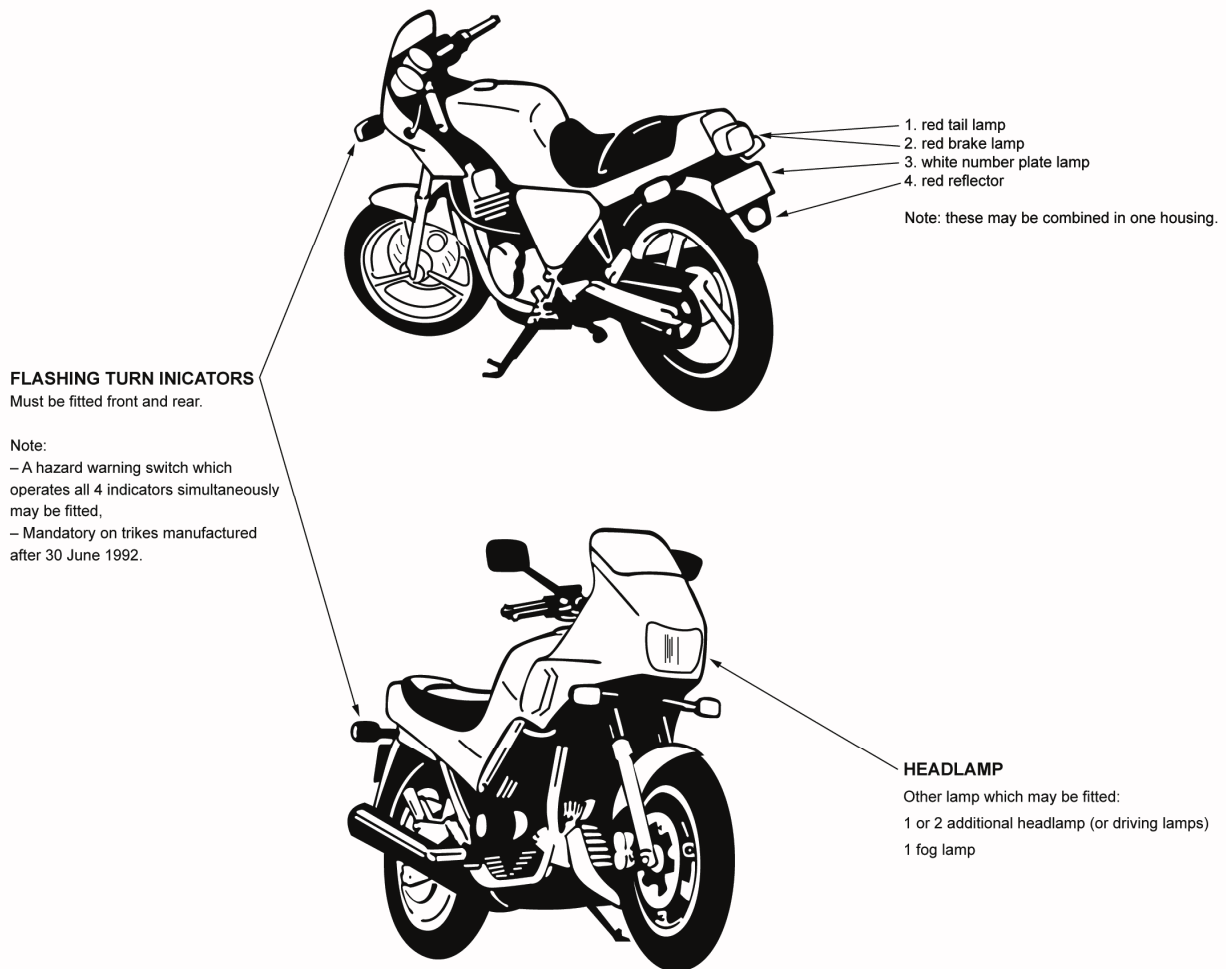

Figure LL3 Lighting Requirements for Motor Cycles

2.1.13 Handlebars

The handlebar must have the same shape and be of the same length on either side of the front wheel and steering head assembly.

Handlebar dimensions have to be limited to ensure that the rider has adequate control over the motor cycle at all times.

Motor cycles manufactured before 1 July 1988 (Figure LL5):

The distance between the extreme ends of the handlebar (V) must not be less than 550mm.

The highest point on the handlebar must not be more than 380mm (W) above the top of the steering yoke.

Where the highest point of the handlebar is more than 205mm vertically above the top of the steering yoke (W), the distance between the extreme ends of the handle bar (V) must not be less than 660mm.

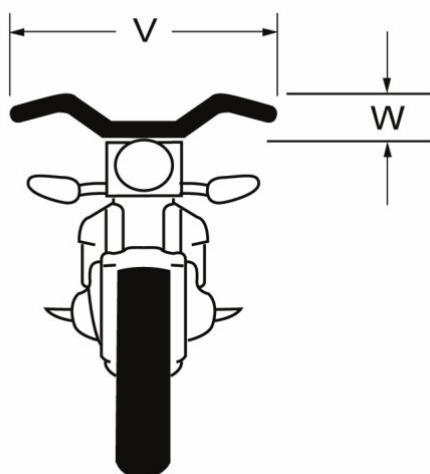

Dimension (V) must not be less than 500mm and not more than 900mm.

Dimension (W) must not be greater than 380mm.

Note: If (W) is greater than 205mm then (V) must not be less than 660mm.

Do not fit handlebars that are outside these limits.

Figure LL5 Motor Cycles Manufactured Before 1 July 1988

Motor cycles manufactured after 30 June 1988 (Figure LL6):

The distance between the extreme ends of the handlebar (X) must not be less than 500mm and not more than 900mm.

The height of the lowest part of the handgrip must not be more than 380mm above the lowest part of the upper surface of the rider's seat (Y).

The horizontal distance between the mid-point of the steering yoke bearing and a point vertically above the centre of the front wheel must not exceed 550mm.

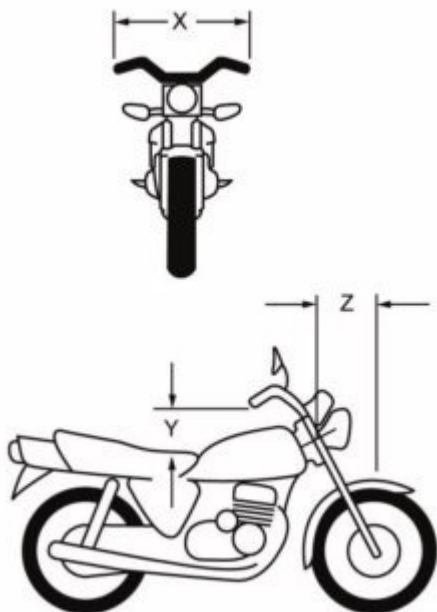

Dimension (X) not less than 500mm and not more than 900mm.

Dimension (Y) not greater than 380mm.

Dimension (Z) not greater 550mm.

Do not fit handlebars that are outside of these limits.

Figure LL6 Motor Cycles Manufactured After 30 June 1988

2.1.14 Tyres and Rims

Each tyre and rim must be strong enough to support the machine when it is fully loaded.

2.1.15 Noise

Motor cycles manufactured from 1 July 1975 are subject to strict design requirements for noise emissions. Components affecting noise emissions (especially exhaust systems) must not be modified and must be maintained in a serviceable condition. Any replacement component must be as near as practical to the original component specification.

The AVSR sets stationary noise limits for all motor vehicles including motor cycles. The stationary noise level for a motor cycle or a motor trike, built after February 1985, is 94 dB(A) or for any other motor cycles or motor trikes, 100 dB(A). Refer to Section LT *Test Procedures* for details about the stationary noise test.

Exhaust system should therefore not be replaced or modified if this is likely to increase the vehicle's noise output beyond that of the unmodified system when in good condition.

Motor cycles manufactured from 1 July 1988 have all components of the Silencing System marked with the name or trade name of the manufacturer. Every motor cycle manufactured after 1 July 1988 carries details of the ADRs 39/... and 83/... stationary noise test in a format similar to that shown in Figure LL7.

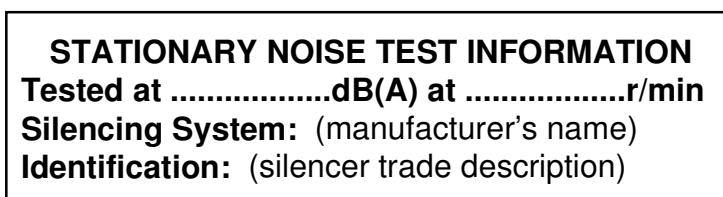

Figure LL7 Stationary Noise Test Information Decal

Any replacement part of the system must show the trademark or the name of the manufacturer of the system.

2.1.16 Horn

An efficient horn or other device must be fitted that is capable of warning other road users of the presence or position of the motor cycle. Horns, sirens or other devices that emit a sound like a siren, exhaust whistle, compression whistle or repeater horn must not be fitted.

2.1.17 Speedometer

Motor cycles manufactured after 30 June 1988 must have an accurate speedometer calibrated in km/h.

2.2 FABRICATION

All work must be performed in accordance with recognised engineering standards. Cutting, heating, welding or bending of components should be avoided by choosing unmodified production components wherever possible.

2.2.1 Welding, Fasteners and Electroplating

Mandatory requirements and guidance on the above items are contained in Section LZ *Appendices*.

- For the use of fasteners refer to Appendix A *Fasteners*;
- For welding techniques and procedures refer to Appendix C *Heating and Welding of Steering Components*; and
- For electroplating refer to Appendix D *Electroplating*.

3 AUSTRALIAN DESIGN RULES

A modified vehicle must continue to comply with the ADRs to which it was originally constructed, except as allowed for in the AVSR.

Outlined in Table LL1 below are requirements and/or components of the vehicle that may be affected by the modifications and that may require re-certification, testing and/or data to show continuing compliance for the modified vehicle. This is not an exhaustive list and other modifications may also affect ADR compliance.

Table LL1 Summary of items that if modified, may detrimentally affect compliance with applicable ADRs

ADRS	DETAILS
ADR 7, 7/...	Hydraulic Brake Hoses
ADR 28x, 28/...	Motor Vehicle Noise
ADR 33x, 33/...	Motor cycle Braking Systems
ADR 39x, 39/...	Motor cycle Noise
ADR 42/...	General Safety Requirements
ADR 57/...	Special Provisions for L-group Vehicles
ADR 83/...	External Noise

To determine the ADRs that apply to the vehicle in question, refer to the applicability tables in Section LO. Vehicles manufactured on or after 1 January 1969 and prior to 1 July 1988 need to comply with the Second Edition ADRs whilst vehicles manufactured after this date need to comply with the Third Edition ADRs. Section LO has separate applicability tables for each edition.

Alternatively, ADR applicability tables for individual vehicle categories may be referenced on the Department of Infrastructure and Transport *RVCS* website at the following address and under the section titled *ADR Applicability Tables*:

<http://rvcs.dotars.gov.au/>

4 NON-CERTIFIED MODIFICATIONS

The following modifications may be carried out provided they do not affect compliance with ADRs and provided they meet the general safety requirements specified in Subsection 2 *General Requirements*, and in the case of seat conversions, the additional requirements specified in Subsection 5 *Specific Requirement for Seat Conversions*.

4.1 OPTIONAL COMPONENTS OFFERED BY THE MANUFACTURER

The following is a list of typical optional components offered by manufacturers of motor cycles.

- Engine;
- Transmission;
- Front and Rear Suspensions;
- Exhaust;
- Fuel tank;

5 SPECIFIC REQUIREMENTS FOR SEAT CONVERSIONS

The following are specific requirements that need to be followed for seat conversions.

All work must also comply with the general guidelines contained in sub-section 2 *General Requirements*.

5.1 CONVERSION FROM TWO SEATER TO SINGLE SEATER

For a two seater motor cycle to be converted to a single seater, it is necessary to shorten the seat and remove the pillion foot pegs/mounting brackets. For a motor cycle to be classified as a single seater, it is necessary for the motor cycle to be fitted with only:

- one seat which has a length less than 500mm; and
- one pair of foot pegs and mountings.

5.1.1 Reduction in Seat Length

Only the upholstered section of the seat needs to be shortened.

The maximum length of the upholstered section of the seat is 500mm.

The shortened seat must have no sharp edges or protrusions.

Any equipment or fittings exposed by the seat modifications must be protected if they are likely to cause injury to any person.

5.1.2 Removal of Foot Pegs and Mounting Brackets

The foot pegs must be removed.

There must be no sharp edges, damage to the frame, or damage to the trailing arms.

These modifications must not incorporate oxy-cutting or application of heat.

5.2 CONVERSION FROM A SINGLE SEATER TO A TWO SEATER ORIGINAL

When converting a motor cycle (which has been previously modified to a single seater) to a two seater, it should be restored as close as possible to the original manufacturer's specifications.

5.2.1 Increase in Seat Length

The seat must be returned to original motor cycle manufacturer's specification or equivalent.

The lengthened seat must have no sharp edges or protrusions.

Any equipment or fittings exposed by the seat modifications must be protected if they are likely to cause injury to any person.

5.2.2 Fitting of Foot Pegs and Mounting Brackets

Pillion passenger foot pegs must be fitted as close to the motor cycle manufacturer's original position as possible.

The foot pegs are to be mounted in accordance with good automotive practice.

There must be no sharp edges, damage to the frame, or damage to the trailing arms.

These modifications must not incorporate oxy-cutting or application of heat.

6 CERTIFIED MODIFICATIONS (LL CODES)

There are currently no certified modifications in this Section of VSB 14.